

**University of Michigan –Dearborn
Mail Services
593-5481**

POSTAL RATE INCREASE EFFECTIVE MAY 12, 2008

Here is a brief summary of the new pricing for the most commonly used services:

- *Letter – First Ounce \$.42
- **Flat – First Ounce \$.83
- Each Additional Ounce \$.17
- Post Card \$.27
- Priority (up to 1 lb.) \$4.80
- Express Mail (up to ½ lb) \$16.25

INTERNATIONAL AIRMAIL

- Canada & Mexico 1 oz. \$.72
- Other Countries 1 oz. \$.94

The shape of the mailpiece will play a larger role in the pricing of First-Class Mail. The new rate design recognizes that each of these shapes has substantially different processing costs and should have separate prices. Here is a brief description of the difference between letters and flats as well as diagrams of each piece as defined by the Post Office:

*Letter: A piece of mail smaller than 6 1/8" in height x 11 1/2" in length. This will cost \$.42 for the first ounce and \$.17 for each additional ounce.

**Flat: A piece of mail larger than 6 1/8" in height x 11 1/2" in length but no larger than 12" in height and 15" in length. This will cost \$.83 for the first ounce and \$.17 for each additional ounce.

Example: One piece of paper in a #10 envelope, 4" x 9 1/2" (less than an ounce) costs \$.42
 One piece of paper in a 9 x 12 envelope (less than an ounce) costs \$.83

DIAGRAMS OF LETTERS AND FLATS

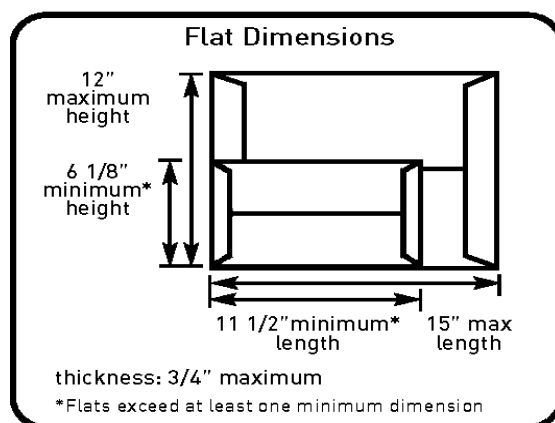
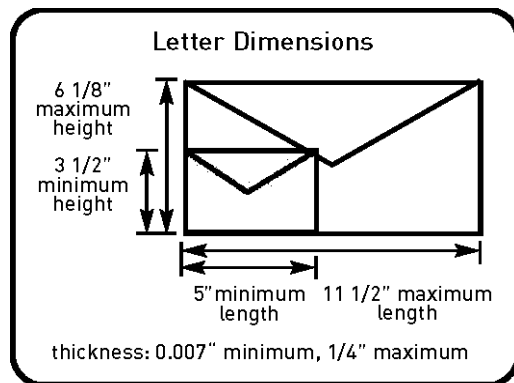

Please contact the mailroom if you have questions regarding other cost saving methods of preparing mail.